

# HANDBOOK OIL CONTROL SYSTEM



# HANDBOOK OIL CONTROL SYSTEM



February 2009

## INDEX

<b>Oil Control Systems</b>	<b>5</b>
<b>Oil Separators</b>	<b>6</b>
<b>Oil Reservoirs</b>	<b>10</b>
<b>Oil Reservoir Pressure Valves</b>	<b>12</b>
<b>Mechanical Oil Level Regulators</b>	<b>13</b>
<b>Strainers</b>	<b>16</b>
<b>Liquid Indicators</b>	<b>17</b>

## FROM QUALITY OUR NATURAL DEVELOPMENT

After more than forty years in the industry of Refrigeration and Air Conditioning components, Castel Quality Range of Products is well known and highly appreciated all over the world.

Quality is the main issue of our Company and it has a special priority, in every step, all along the production cycle.

We produce on high tech machinery and updated automatic production lines, operating in conformity with the safety and environmental standards currently enforced.

Castel offers to the Market and to the Manufacturers fully tested products suitable with HCFC and HFC Refrigerants currently used in the Refrigeration & Air Conditioning Industry.

UNI EN ISO 9001:2000 issued by ICIM certifies the Quality System of the Factory. Moreover Castel Products count a number of certifications in conformity with EEC Directives and with European and American Quality Approval.

## EXTERNAL LEAKAGE

All the products illustrated in this Handbook are submitted, one by one, to tightness tests besides to functional tests.

Allowable external leakage, measurable during the test, agrees to the definition given in the Standard EN 12284: 2003, Par. 9.4:

“During the test, no bubbles shall form over a period of at least one minute when the specimen is immersed in water with low surface tension, ...”.

## PRESSURE CONTAINMENT

All the products illustrated in this Handbook, if submitted to hydrostatic test, guarantee a pressure strength at least equal to 1,43 x PS in compliance with the Directive 97/23/EC.

All the products illustrated in this Handbook, if submitted to burst test, guarantee a pressure strength at least equal to 3 x PS according to EN 378-2: 2008 Standard. A great number of products illustrated in the Handbook can guarantee an higher pressure strength, equal to 5 x PS according to the Standard UL 207: 2004. (for detailed information about these products please contact Castel Technical Department).

## WEIGHTS

The weights of the items listed in this Handbook include packaging.

## GUARANTEE

All Castel products are covered by a 12 – months warranty. This warranty covers all products or parts thereof that turn out to be defective within the warranty period. In this case, at his own expenses, the customer shall return the defective item with a detailed description of the claimed defects. The warranty doesn't apply if the defect of Castel products are due to mistakes either by customer or by third parties such wrong installations, use contrary to Castel indications, tampering. In case of defects of its own products, Castel will only replace the defective goods and will not refund damages of any kind.

The technical data shown on this catalogue are indicative. Castel reserves the right to modify the same at any time without any previous notice.

The products listed in this handbook are protected according to the law.

## OIL CONTROL SYSTEMS

This handbook is intended for oil control systems installed with reciprocating compressors using:

- HFC refrigerants fluids, particularly R134a, R404A, R407C, R507 mixed with polyolester lubricants
- Old CFC and HCFC refrigerants fluids mixed with mineral lubricants.

A proper oil control system is essential to ensure compressors lubrication and energy efficient cooling. If selected and installed correctly, an oil control system protects the compressors from both low and excess oil levels and avoids expensive replacements of compressors due to incorrect lubrication. Excessive oil in refrigerating system can lead to oil slugging to the compressor, this slugging can damage a compressor as well as liquid refrigerant slugging.

By removing or reducing oil from discharge line, the system efficiency is increased. Large quantities of oil in a refrigeration or air conditioning system reduce the efficiency of the system because:

- oil coating on the condenser and evaporator walls reduces the heat transfer
- oil volume displaces refrigerant volume in system mass flow but oil does not change phase and so is a poor refrigerant

The products shown in this handbook can be used in two oil control systems:

- Single compressor system
- Low pressure oil control system

Single compressor system is the basic oil system. The compressor discharge is piped to the inlet of the oil separator and the outlet of the oil separator is piped to the condenser. Normally a check valve is fitted between oil separator and condenser. An oil return line is connected from the oil separator to the compressor crankcase, through an oil strainer. When the oil level in the separator increases a float valve opens and feeds a small amount of oil, under the discharge pressure, to the crankcase. When the oil level in the separator falls the float valve closes and prevents hot gas from

bypassing to the crankcase.

It is recognized best practice to fit a liquid indicator between separator and crankcase to check the correct working of separator and the oil feed to the crankcase.

Low pressure oil control system is normally used for multi – compressor parallel system. The common discharge line is piped to the inlet of the oil separator and the outlet of the oil separator is piped to the condenser. Normally a check valve is fitted between oil separator and condenser. An oil return line is connected from the oil separator to the top valve of the oil reservoir. A vent line connects the suction line to the oil reservoir, using a pressure valve to reduce the pressure in the reservoir. This pressure valve, mounted on the top head of reservoir, will maintain the reservoir at a set pressure above the suction line. The bottom valve of oil reservoir is piped to the mechanical oil level regulators mounted on the compressor crankcases; one oil strainer is mounted between oil reservoir and each regulator to remove debris from the oil. These regulators open to feed oil as the oil level drops and close as the oil level rises to the set level, controlling the oil level in the compressor crankcases.

It is recognized best practice to fit:

- a liquid indicator between separator and reservoir to check the correct working of separator
- a liquid indicator before each level regulator to check the oil feed to the regulator

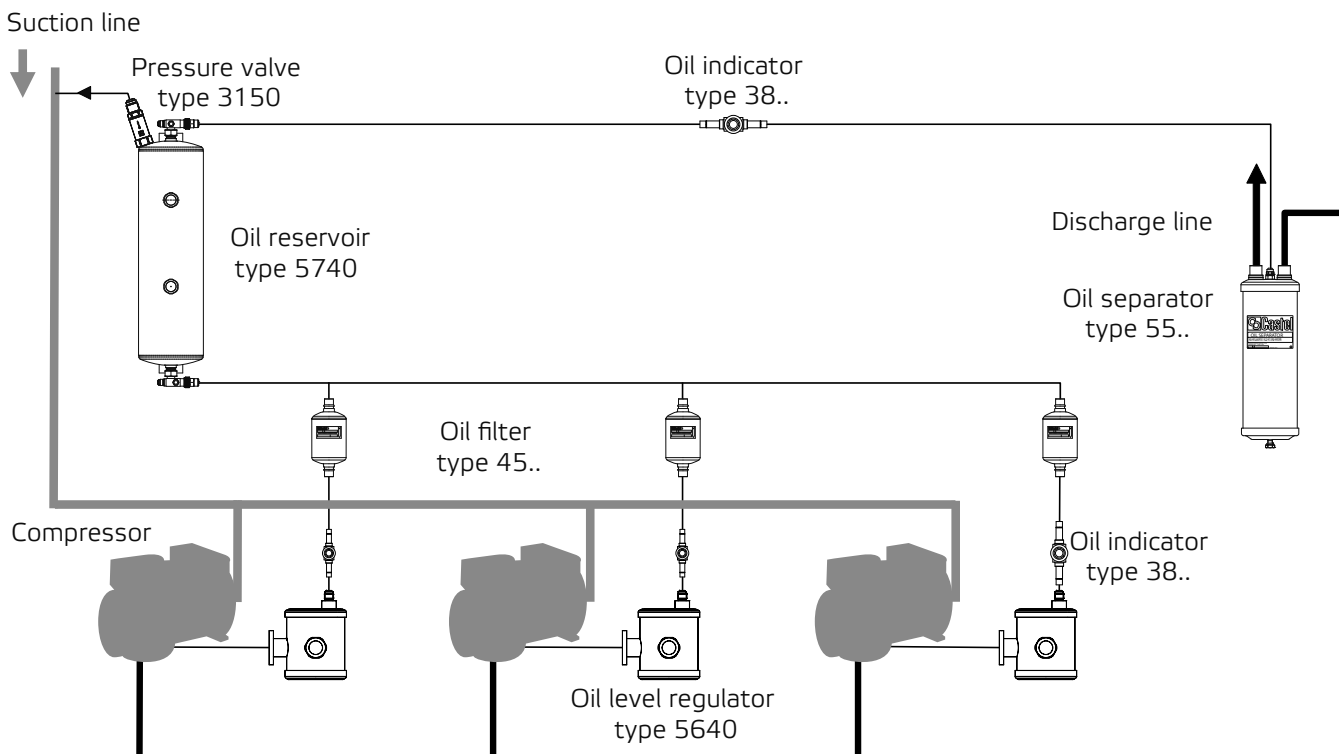

## OIL SEPARATORS

### APPLICATIONS

The oil separators, shown in this handbook, are classified "Pressure vessels" in the sense of the Pressure Equipment Directive 94/23/EC, Article 1, Section 2.1.1 and are subject of Article 9, Section 1.1 of the same Directive.

They are designed for installation on commercial refrigerating systems and on civil and industrial conditioning plants, which use refrigerant fluids proper to the Group II (as defined in Article 9, Section 2.2 of Directive 97/23/EC and referred to in Directive 67/548/EEC).

The advantages of the oil separator on the discharge line of a compressor in a refrigeration system are confirmed by many years of experience. The oil separator intercepts the oil mixed with compressed gas and returns it to the oil reservoir or directly to the compressor crankcase thus assuring an efficient lubrication of its moving parts. Furthermore, the oil separator maintains a high coefficient of condenser and evaporator performance by almost completely removing oil deposits from their exchange surfaces. When a very high temperature at the end of the compression stage leads to the formation of oil vapours, a separator with a capacity exceeding the values shown in the table should be used. Moreover, the oil separator, damping the valves pulsations, reduces system noise with an open or semi-hermetic compressor.

Finally, the use of an oil separator leads to:

- a longer life of the compressor;
- a better performance of the whole system with consequent energy saving;
- a quieter operation by reducing pulsations.

Tables 1 and 3 show the technical data relating to the working conditions of oil separators.

### CONSTRUCTION

Castel manufactures two types of oil separators:

- separators series 5520 can be overhauled for maintenance and can be replaced from the system. They are equipped with threaded connections, which can mate to the connections type 5590 (to be ordered separately)

- separators series 5540 are closed type and they cannot be dismantled from the system, except cutting the piping.

The body is manufactured from steel pipe of adequate thickness. Flanges and cover are also made of steel.

Either threaded connections of separators series 5520 or solder connections of separators series 5540 are manufactured, machining, with steel bar EN 10277-3 11S Mn Pb 37 + C.

The internal device is simple in order to assure a trouble-free long operation.

Appropriate metallic screens, placed on the inlet and outlet, rapidly reduce gas speed, and create the conditions required for the separation of the oil from the refrigerant. A float operated needle valve, set on the bottom of the vessel, returns the oil to the crankcase of compressor. The bottom also includes a chamber that collects all metallic debris. A permanent magnet holds these impurities to avoid they stop or damage the operation of needle, moved by floating.

### SELECTING THE SIZE OF AN OIL SEPARATOR

The selecting of an oil separator should be done comparing the characteristics of the installed compressor, establishing:

- inlet connection must agree with the discharge diameter of the compressor
- refrigerant flow capacity with fixed working conditions (saturated discharge temperature, saturated suction temperature, eventually liquid subcooling, sucked vapour overheating). Table 3 has being written following this principle.

This is necessary to define the gas speed referred to the cross section of oil separator, assigned an end compression temperature. It is advisable the above-mentioned speed doesn't exceed 0,4 m/s, to avoid great swirl phenomena.

Generally, fixed the following data: refrigerating capacity of compressor, type of refrigerant and working conditions, the volumetric capacity  $Q$ , of compressed gas, is given by:

$$Q = \frac{P}{\Delta H} \times v_g \quad [\text{m}^3/\text{s}] \quad \text{with:}$$

- $P$  = refrigerant flow capacity [kW]
- $\Delta H$  = heat content differential, see diagram (fig. 1). [kJ/kg]
- $v_g$  = specific volume of compressed gas, separator inlet (fig. 1). [m<sup>3</sup>/kg]

Check of gas speed, referred to the cross section of oil separator, is given by:

$$v = \frac{Q}{S} \quad [\text{m/s}] \quad \text{with:}$$

- $S$  = gross cross section of shell separator [m<sup>2</sup>]

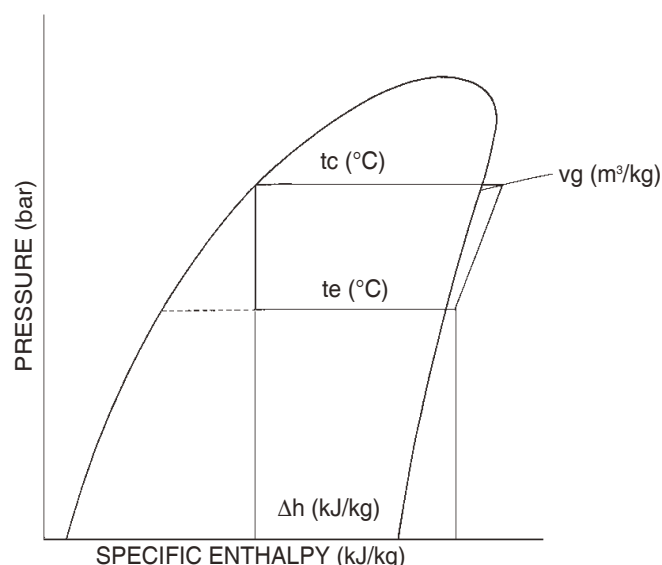

■ Fig. 1



## INSTALLATION

The oil separators type 5520 and 5540 should be installed in the discharge line between the compressor and the condenser mounted securely in a vertical position and reasonably close to the compressor.

To prevent the return of refrigerant from condenser, during the off cycle of the system, it's advisable to install a check valve between the condenser and oil separator outlet connection.

Oil separator performs best when operating at or near the compressor discharge temperature. In location the oil separator, choose a position to avoid, as far as possible, chilling of the shell, which may result in condensing of liquid within the separator. If this is not possible, it is advisable to supply the separator with the better solutions (insulation, strap heater, others) to prevent the refrigerant in the system from condensing in the shell. Before the oil separator is installed, either one 5520 or one 5540, an initial charge of oil should be added to it. Refer to general characteristics of oil separators or to instruction sheet for the proper amount of oil. Oil pre-charge is very important, failure to pre-charge separator sump may result in damage to the oil return float mechanism. Use the same type of oil that is in the compressor crankcase.

Acting as the lay out of refrigerating system, the return line may be run from the oil fitting to:

- The compressor crankcase
- The suction line upstream the compressor or upstream the receiver, if present
- The oil reservoir if oil control system is being used.

A sight glass may be installed in the oil line, in a position that oil is flowing through the tube, to check the correct working of the oil separator.

■ 5540

**TABLE 1: General Characteristics of Oil Separators**

Catalogue Number	Solder Connections				Couple of solder connections IN / OUT			Oil connection [SAE Flare]	Oil addition [kg]	Max. differential pressure [bar]	TS [°C]		PS [bar]	Risk Category according to PED
	ODS		ODM		Catalogue Number	ODS (1)					min.	max.		
	Ø [in.]	Ø [mm]	Ø [in.]	Ø [mm]		Ø [in.]	Ø [mm]							
5540/4	1/2"	-	5/8"	16	-	-	-	1/4"	0,4 / 0,5	21	- 10	+ 130	45	I
5540/5	5/8"	16	3/4"	-										
5540/7	7/8"	-	1"	-										
5540/9	1.1/8"	-	1.3/8"	35										
5540/11	1.3/8"	35	1.5/8"	-				3/8"	0,6 / 0,7					
5540/13	1.5/8"	-	-	-										
5540/M42	-	42	-	-										
5540/17	2.1/8"	54	-	-				5590/5	5/8"				16	1/4"
5520/C	-				5590/7	7/8"	-							
5520/D	-				5590/9	1.1/8"	-							
	-				5590/11	1.3/8"	35							
5520/E	-				5590/13	1.5/8"	-	5590/M42	-	42				

(1): The dimensions of the separator's connections must agree with the discharge diameter of the compressor



**TABLE 2: Dimensions and Weights of Oil Separators**

Catalogue Number		Solder Connections		Dimensions [mm]					Weight [g]	
Separator	Connections	ODS		Ø D1	Ø D2	H1	H2	H3		H4
		Ø [in.]	Ø [mm]							
5540/4	-	1/2"	-	123	-	17.5	-	-	280	4200
5540/5		5/8"	16						367	4960
5540/7		7/8"	-						428	5030
5540/9		1.1/8"	-						471	5835
5540/11		1.3/8"	35	481					5800	
5540/13		1.5/8"	-							
5540/M42		-	42							
5540/17		2.1/8"	54							
5520/C	5590/5	5/8"	16	121	149	17.5	336	61	397	6980
	5590/7	7/8"	-							
5520/D	5590/9	1.1/8"	-				391	67	458	7760
	5590/11	1.3/8"	35							
5520/E	5590/13	1.5/8"	-					92	483	7680
	5590/M42	-	42							

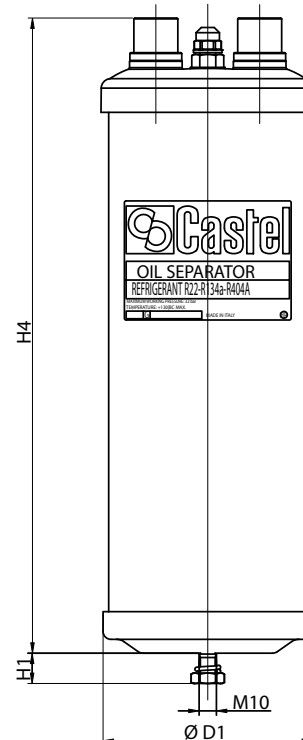
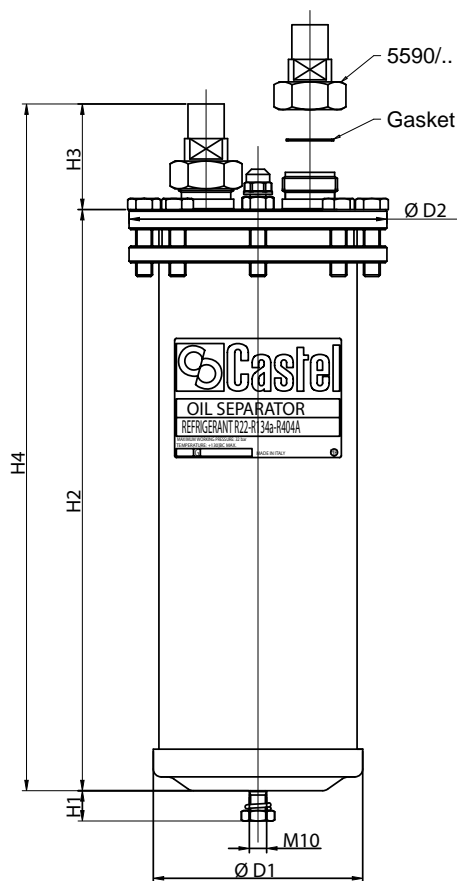

■ 5520

■ 5540

**TABLE 3: Refrigerant Flow Capacity**

Catalogue Number	Catalogue Number of solder connections	Refrigerant Capacity (1) [kW]							
		R134a		R22		R404A		R407C	
		Evaporating Temperature [°C]							
		- 20	+ 5	- 40	+ 5	- 40	+ 5	- 40	+ 5
5540/4	-	5.3	6.1	6.4	7.9	6.4	8.8	6.0	8.0
5540/5		16.4	18.9	19.7	24.5	19.9	27.3	18.6	24.6
5540/7		18.6	21.3	22.2	27.7	22.5	30.8	21.0	27.8
5540/9		21.2	24.3	25.4	31.5	25.7	35.2	24.6	31.8
5540/11		23.9	27.4	28.6	35.6	28.9	39.6	27.0	35.8
5540/13		33.1	38.0	39.6	49.3	40.1	54.9	37.6	49.6
5540/M42		42.5	48.8	50.9	63.4	51.5	70.6	48.3	63.7
5540/17		42.5	48.8	50.9	63.4	51.5	70.6	48.3	63.7
5520/C	5590/5	16.4	18.9	19.7	24.5	19.9	27.3	18.6	24.6
	5590/7	18.6	21.3	22.2	27.7	22.5	30.8	21.0	27.8
5520/D	5590/9	21.2	24.3	25.4	31.5	25.7	35.2	24.6	31.8
	5590/11	23.9	27.4	28.6	35.6	28.9	39.6	27.0	35.8
5520/E	5590/13	26.5	30.4	31.8	39.5	32.1	44.0	30.0	40.0
	5590/M42								

(1): Refrigerant flow capacity with a condensing temperature of + 40°C and normal overheating values of vapour sucked by compressor. No liquid subcooling.  
Maximum pressure drop of 0,15 bar

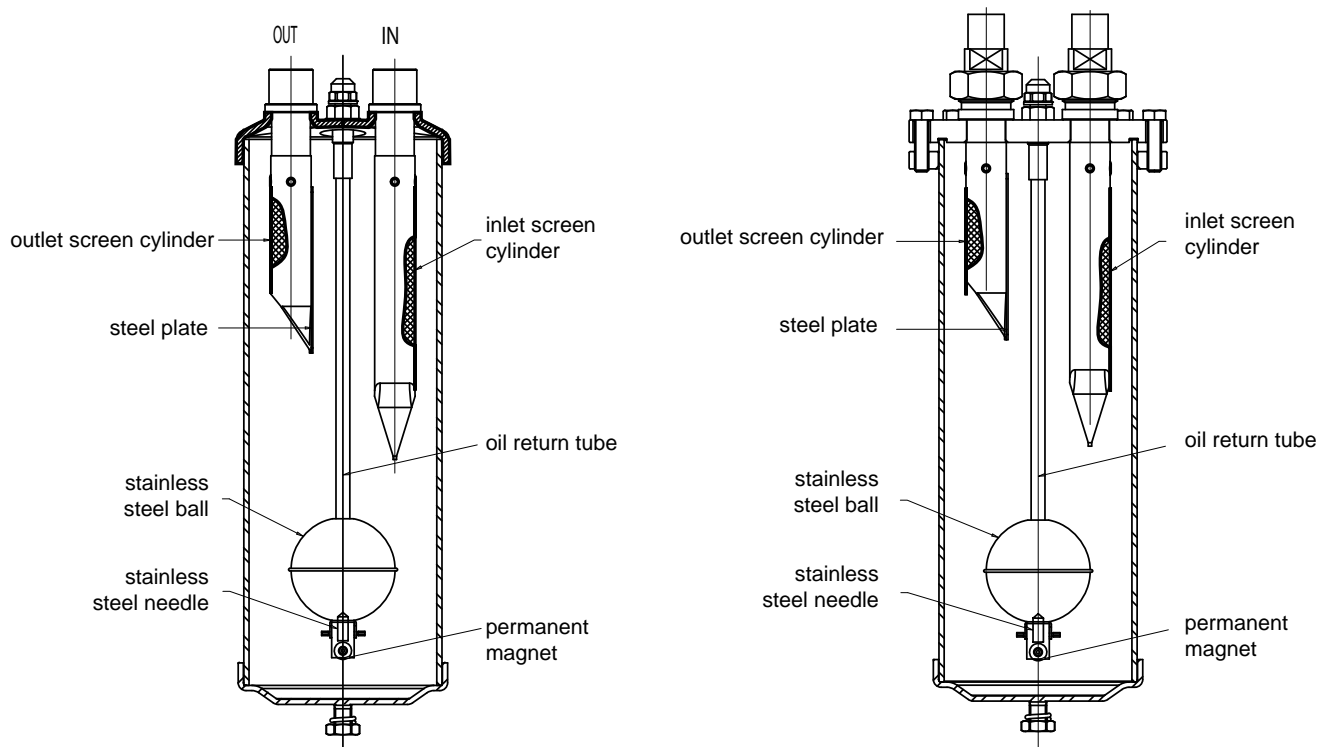

■ 5540

■ 5520

## OIL RESERVOIRS

### APPLICATIONS

The oil reservoirs, shown in this handbook, are classified "Pressure vessels" in the sense of the Pressure Equipment Directive 94/23/EC, Article 1, Section 2.1.1 and are subject of Article 3, Section 1.1 of the same Directive.

They are installed on commercial refrigerating systems and on civil and industrial conditioning plants, which use refrigerant fluids proper to the Group II (as defined in Article 9, Section 2.2 of Directive 97/23/EC and referred to in Directive 67/548/EEC).

These reservoirs are used in "Low pressure oil control systems" and provide a holding charge of oil. The amount of oil circulating in a refrigerating system varies depending on the operating conditions. The oil reservoir caters for these fluctuations by providing additional storage capacity.

### CONSTRUCTION

Castel manufactures three types of oil reservoirs:

- 5740/2G: with a nominal volume of 2 US Gallons
- 5740/3G: with a nominal volume of 3 US Gallons
- 5740/4G: with a nominal volume of 4 US Gallons

The three types are supplied with:

- Two sight glasses with level indicator balls inside, to check the oil level in the reservoir. These glasses are already screwed on the vessel by the manufacturer.
- Two rotalock valves to easy connect oil fill and oil drain. These valves are not mounted on the reservoir but are supplied in the package, completed by the proper PTFE gaskets. The customer can assemble the rotalock valves on the reservoir according to his preferred working position.
- A 3/8" SAE Flare connection on the top of the reservoir to allow the assembling of a pressure vent valve.

Pressure vent valve is not supplied with reservoir; if it's necessary to maintain a positive differential pressure between the reservoir and the compressor crankcase the customer can select two different models:

- 3150/X01 (with differential pressure of 0,35 bar)
- 3150/X02 (with differential pressure of 1,4 bar)

Screwing the vent valve onto the 3/8" SAE connection, remember to use the copper gasket 7580/3 between reservoir and valve.

The reservoir body is manufactured from carbon steel pipe of adequate thickness. Top and bottom are also made from carbon steel. All threaded connections are manufactured, machining, with steel bar EN 10277-3 11S Mn Pb 37 + C.

The rotalock valves have two additional service connections, 1/4" SAE Flare; one of them can be excluded by the back sealing of the spindle. The valve body and spindle are manufactured, machining, with steel bar EN 10277-3 11S Mn Pb 37 + C.

### INSTALLATION

On new system start-up oil should be added to the oil reservoir to the upper sight glass. During the first two working days of the refrigerating system, oil should be added to maintain a level



■ 5740

**TABLE 4: General Characteristics of Oil Reservoirs**

Catalogue Number	Connections			Volume		TS [°C]		PS [bar]	Risk Category according to PED
	Oil fill	Oil drain	Pressure vent valve	US Gallons	[l]	min.	max.		
5740/2G	1 "UNS for 3/8" SAE Flare rotalock valve	1 "UNS for 3/8" SAE Flare rotalock valve	3/8" SAE Flare	2	7.56	- 10	+ 130	32	Cat. II
5740/3G				3	11.34				
5740/4G				4	15.14				

between the two sight glasses. This procedure may require several charges as the oil is adsorbed in the refrigerant and coats the low side tubing. When the refrigerating system is balanced the oil level in the reservoir must be controlled during every maintenance inspection and oil should be added again if level falls below the lower sight glass.

When adding or replacing an oil reservoir to an existing system,

it should only be filled to the top of the lower sight glass. As the system is placed into operation, the oil level should be observed during the first two days. If the level decreases below the lower sight glass, some oil should be added to the reservoir. If the level rises above the upper sight glass, some oil should be drained from the reservoir.

**TABLE 5: Dimensions and Weights of Oil Reservoirs**

Catalogue Number	Dimensions [mm]								Weight [g]
	A	B	C	Ø D	H1	H2	H3	H4	
5740/2G	169	155	202.5	165	468	420	380	488	8166
5740/3G	244	220	202.5	165	658	610	570	678	11714
5740/4G	194	190	256.5	219	558	450	470	578	11110

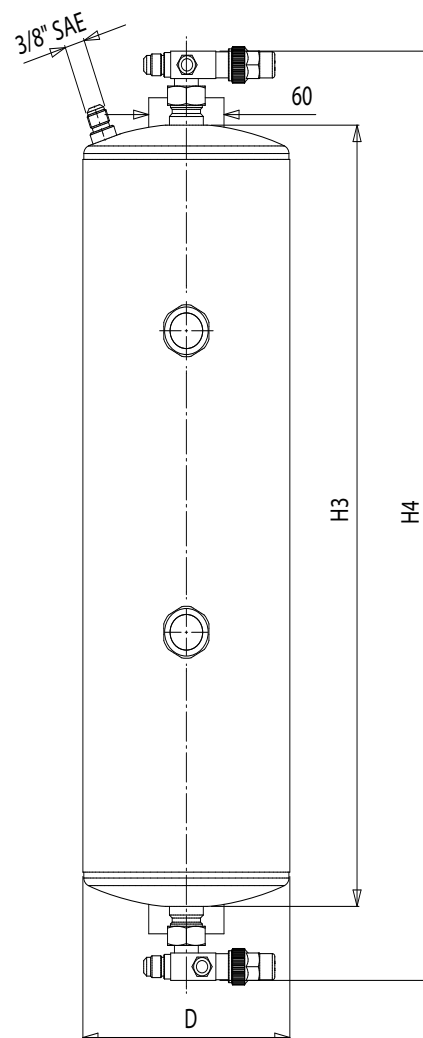
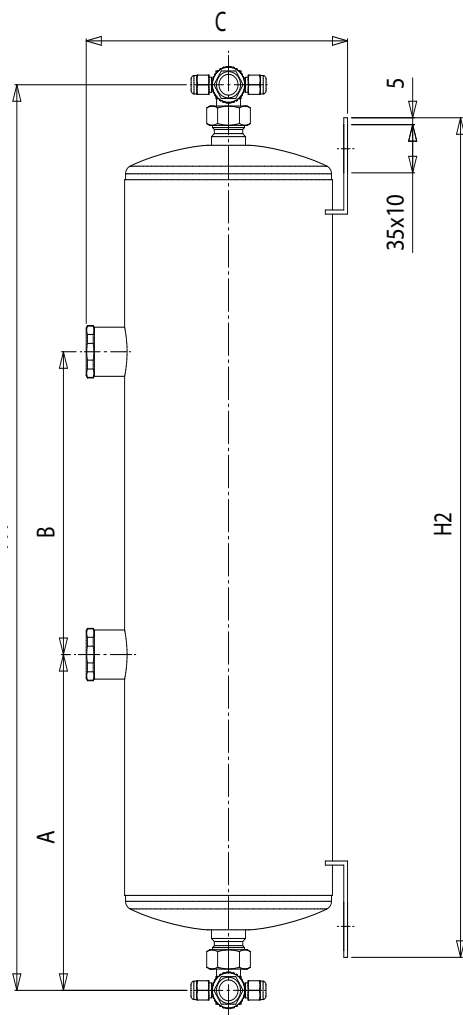

■ 5740

## OIL RESERVOIR PRESSURE VALVES

### APPLICATIONS

The reservoir pressure valves, shown in this handbook, are classified "Pressure accessories" in the sense of the Pressure Equipment Directive 94/23/EC, Article 1, Section 2.1.4 and are subject of Article 3, Section 1.3 of the same Directive.

These valves are designed for use in "Low pressure oil control systems" and are installed on commercial refrigerating systems and on civil and industrial conditioning plants, which use refrigerant fluids proper to the Group II (as defined in Article 9, Section 2.2 of Directive 97/23/EC and referred to in Directive 67/548/EEC).

### CONSTRUCTION

Castel manufactures two reservoir pressure valves with the same body but two differential pressures. Higher pressure differential will increase the oil flow rate from the oil reservoir back to the compressor crankcase.

The model's selection has to take into account individual compres-

or crankcase pressures along with the differential pressure range of the oil regulators.

The main parts of the valves are made with the following materials:

- Hot forged brass EN 12420 – CW 617N for body
- Austenitic stainless steel AISI 302 for the spring
- Fluorcarbon rubber (FPM) for outlet seal gaskets.
- P.T.F.E. for seat gasket

### INSTALLATION

These valves are used to vent pressure in the oil reservoir while still maintaining a positive pressure differential between the reservoir and the compressor crankcase. This positive pressure ensures an adequate oil supply to the mechanical oil level regulator. The reservoir pressure valve is directly mounted on the 3/8" SAE Flare connection of the reservoir and is piped to the suction line.



■ 3150

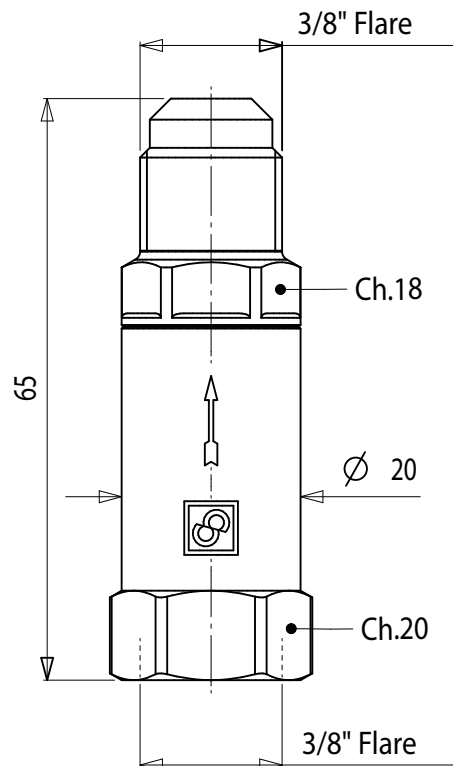

■ 3150

**TABLE 6: General Characteristics of Oil Reservoir Pressure Valves**

Catalogue Number	SAE Flare Connections		Kv Factor [m³/h]	Pressure Differential [bar]	TS [°C]		PS [bar]	Risk Category according to PED
	IN	OUT			min.	max.		
3150/X01	3/8"- F	3/8"- M	1.6	0.35	- 40	+105	45	Art. 3.3
3150/X02				1.4				

## MECHANICAL OIL LEVEL REGULATORS

### APPLICATIONS

The mechanical oil level regulators, shown in this handbook, are classified "Pressure vessels" in the sense of the Pressure Equipment Directive 94/23/EC, Article 1, Section 2.1.1 and are subject of Article 3, Section 1.1 of the same Directive.

They are installed on commercial refrigerating systems and on civil and industrial conditioning plants, which use refrigerant fluids proper to the Group II (as defined in Article 9, Section 2.2 of Directive 97/23/EC and referred to in Directive 67/548/EEC).

These regulators are used in "Low pressure oil control systems" and are designed for use with reciprocating compressors; they are not recommended for scroll compressors.

### CONSTRUCTION

Castel manufactures four types of mechanical oil level regulators:

- 5640/A: non adjustable oil level regulator, equipped with one 3/8" SAE flare connection on the top, for oil feed, and two special flanged connections on the shell, right angle. One of these flanges can be fitted directly to the compressor crankcase that uses a standard 3 or 4 bolt sight glass. The compressor sight glass may be connected to the other free flange.

- 5640/B: non adjustable oil level regulator, equipped with one 3/8" SAE flare connection on the top, for oil feed, one special flanged connection plus two screwed sight glasses on the shell. The flange can be fitted directly to the compressor crankcase that uses a standard 3 or 4 bolt sight glass. The compressor sight glass is not necessary

- 5640/C: non adjustable oil level regulator, equipped with one 3/8" SAE flare connection on the top, for oil feed, one special flanged connection plus one screwed sight glasses on the right of shell. The flange can be fitted directly to the compressor crankcase that uses a standard 3 or 4 bolt sight glass. The compressor sight glass is not necessary

- 5640/D: non adjustable oil level regulator, equipped with one 3/8" SAE flare connection on the top, for oil feed, one special flanged connection plus one screwed sight glasses on the left of shell. The flange can be fitted directly to the compressor crankcase that uses a standard 3 or 4 bolt sight glass. The compressor sight glass is not necessary

The internal device is simple in order to assure a trouble-free long operation. Oil is fed to the regulator via the 3/8" SAE flare connection on the top. An internal needle valve allows or shuts off the oil supply to the regulator and a ball float controls the position of this needle valve. During compressor working the crankcase oil level reduces, this reduction activates the regulator which restores and maintains the level.

The body is manufactured from carbon steel pipe of adequate thickness. Top and bottom are also made from carbon steel. Either threaded connections or flanges connections are manufactured, machining, with steel bar EN 10277-3 11S Mn Pb 37 + C. The ball float is made from stainless steel.

### INSTALLATION

The oil level regulator must be mounted horizontally with the oil inlet pointing upwards. The regulator should not be subjected to excessive vibration, if necessary mount a vibration eliminator between the compressor crankcase and the regulator.

As above mentioned oil regulators series 5640 are designed to attach directly to the sight glass housing on compressor crankcase. If the compressor crankcase has different sight glass configuration, not compatible with regulator flanged connection, Castel supplies to its customers the following adapter kits:

- 5690/X01: two-flange adapter 82 mm length, supplied with one O-Ring. The first flange, with five holes, is fixed meanwhile the second one, with three holes, is mobile.

- 5690/X02: threaded adapter 1.1/8" - 12 UNF supplied with one mobile flange, with three holes, and one O-Ring

- 5690/X03: threaded adapter 1.1/8" - 18 UNEF supplied with one mobile flange, with three holes, and one PTFE gasket

- 5690/X04: threaded adapter 3/4" NPT supplied with one mobile flange, with three holes

Table 8 shows the correspondence between the adapter kits and the compressor models of several manufacturers.



■ 5640

**TABELLA 7: General Characteristics of Oil Level Regulators**

Catalogue Number	Connections			Regulation type	Equalisation	Oil level position	Oil pressure differential (1) [bar]	Volume [l]	TS [°C]		PS [bar]	Weight [g]	Risk Category according to PED
	Compressor Crankcase	Oil level inspection	Oil inlet [SAE Flare]						min.	max.			
5640/A	Flanged with 3 bolts dia 1.7/8" and 4 bolts dia 50 mm	Flanged with 3 bolts dia 1.7/8" and 4 bolts dia 50 mm	3/8"	not adjustable	no	Fixed at 1/2 sight glass	0,35 / 2,1	0.8	- 10	+ 130	32	1900	Art. 3.3
5640/B		2 sight glasses already mounted										1950	
5640/C		1 sight glass already mounted										1850	
5640/D													

(1): Oil pressure differential is the difference between the supply pressure at inlet to the regulator and the pressure inside the compressor crankcase

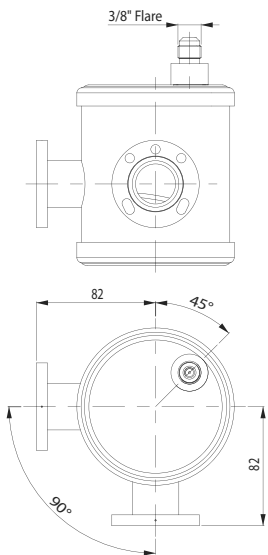

■ 5640/A

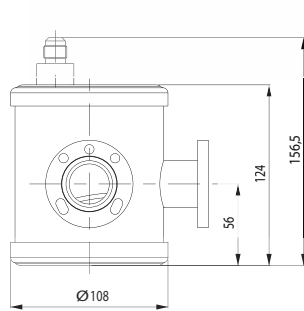

■ 5640/B

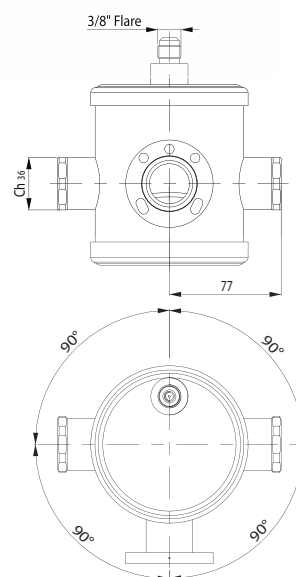

■ 5640/C

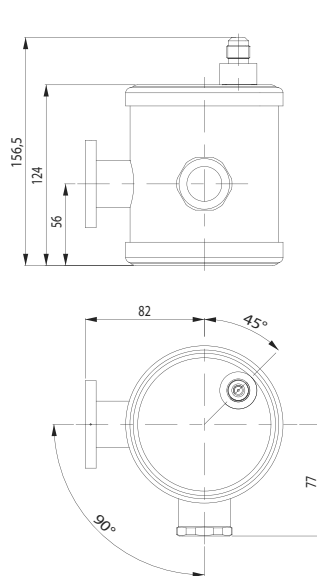

■ 5640/D

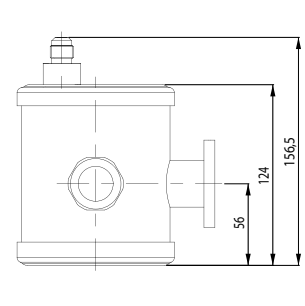
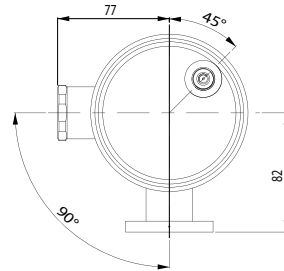
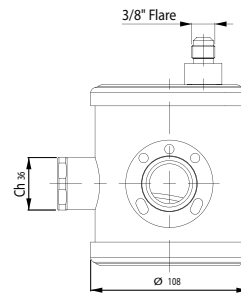
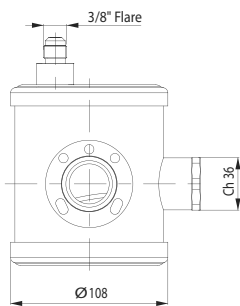

**TABLE 8: Compressors Adapter Kits Requirements**

Compressors		Compressor connection	Adapter kit number
Manufacturer	Model Numbers		
BITZER	from 2CC up to 2KC	1.1/8" - 18 UNEF Thread	5690/X03
	from 4CC up to 4FC		
	ESH		
	from 4NC up to 4VC	3 Bolts, 1.7/8" B.C.	not necessary
	6D, 6E		
	8FC, 8GC		
	2H, 2T, 4H, 4T, 4P		
	4G, 4H, 4J, 6F, 6G, 6H, 6J		
S4, S6,	4 Bolts, 50 mm B.C.	not necessary	
BOCK	HA (from 3 up to 5), HG (from 3 up to 5)	3 Bolts, 1.7/8" B.C.	not necessary
	HG (7 and 8)		
	AM (from 2 up to 5)	4 Bolts, 50 mm B.C.	5690/X01
	F (from 2 up to 16)		
	HA (12, 22, 34), HG (12, 22, 34)	1.1/8" - 18 UNEF Thread	5690/X03
CARRIER	EA, ER, 6E, OBE, OBCC	3 Bolts, 1.7/8" B.C.	not necessary
	D2, D3, D4, D6, 4CC, 6CC	3 Bolts, 1.7/8" B.C.	not necessary
COPELAND	D8, 8CC		5690/X01
	DK, DL, DN, ZR, ZZ	1.1/8" - 12 UNF Thread	5690/X02
	ZB, ZF, ZS	3/4" NPT	5690/X04
	K, KP, 2S, Y	3 Bolts, 1.7/8" B.C.	not necessary
DORIN	H (from 40CC up to 240SB), K (from 40CC up to 280CC)	1.1/8" - 18 UNEF Thread	5690/X03
	BIG 4	3 Bolts, 1.7/8" B.C.	not necessary
DUNHAM BUSH	BIG 4	3 Bolts, 1.7/8" B.C.	not necessary
FRASCOLD	all	3 Bolts, 1.7/8" B.C.	not necessary
MANEUROP	all	1.1/8" - 18 UNEF Thread	5690/X03
REFCOMP	L, OF, SP	3 Bolts, 1.7/8" B.C.	5690/X01
TECUMSEH	P, R, S, PA, RA, SA, CK, CM, CH, CG	1.1/8" - 12 UNF Thread	5690/X02
	TAG, TAH	1.1/8" - 18 UNEF Thread	5690/X03
TRANE	M, R	3 Bolts, 1.7/8" B.C.	not necessary
	K	3/4" NPT	5690/X04
YORK	GC, GS, JS	3 Bolts, 1.7/8" B.C.	not necessary

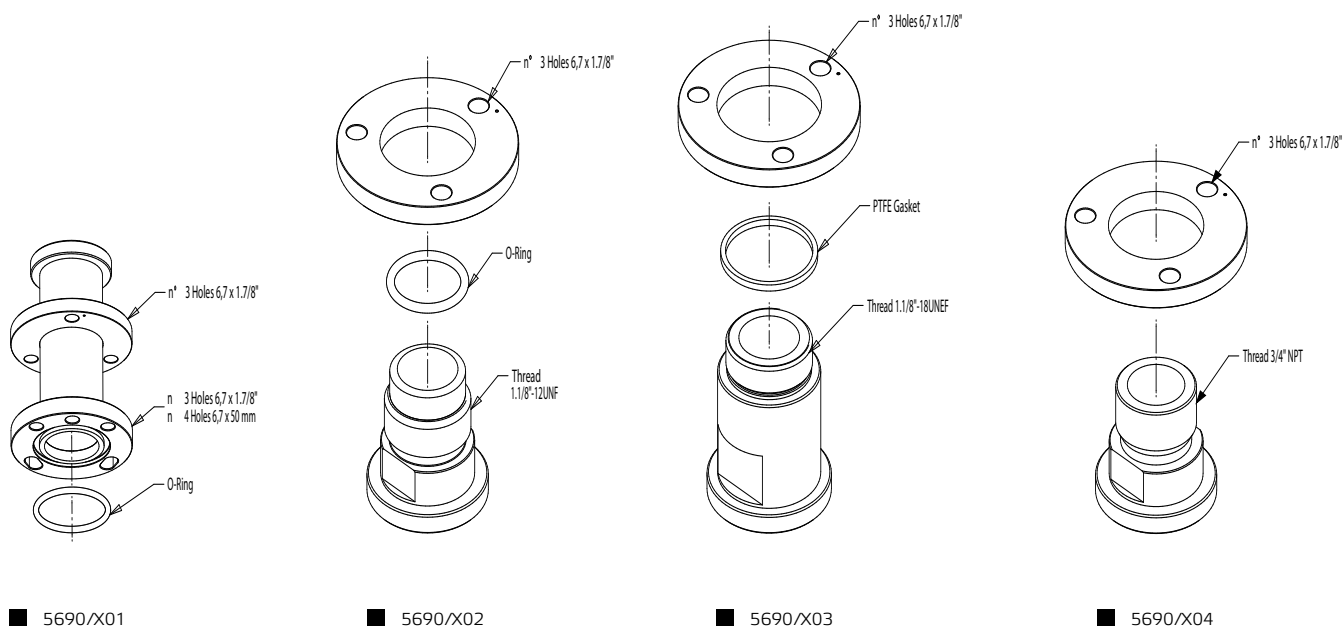



## STRAINERS

### APPLICATIONS

The filters, shown in this handbook, are classified “Pressure vessels” in the sense of the Pressure Equipment Directive 94/23/EC, Article 1, Section 2.1.1 and are subject of Article 3, Section 1.1 of the same Directive.

They are designed for installation on commercial refrigerating systems and on civil and industrial conditioning plants, which use refrigerant fluids proper to the Group II (as defined in Article 9, Section 2.2 of Directive 97/23/EC and referred to in Directive 67/548/EEC).

### CONSTRUCTION

The filter is completely manufactured in steel, either with nickel-plated Flare threaded connections. The product range also includes types with copper plated solder connections, offering the possibility to solder the copper pipe inside the connections (ODS) or outside the connections, using a copper sleeve (ODM).

Inside the filters there is a screen basket, with wide filtering surface, made of austenitic stainless steel AISI 304. These filters may not be cleaned.



■ 4520

**TABLE 9: General Characteristics of Strainers**

Catalogue Number	Filtering Surface [cm <sup>2</sup> ]	Useful Passage Surface [%]	Mesh Opening [mm]	Connections				Kv Factor [m <sup>3</sup> /h]	TS [°C]		PS [bar]	Risk Category according to PED	
				SAE Flare	ODS		ODM		min.	max.			
					Ø [in.]	Ø [mm]	Ø [in.]						Ø [mm]
4510/3	58	36.6	0.166	3/8"	-	-	-	-	-40	+80	45	Art. 3.3	
4520/3				-	3/8"	-	1/2"	-					
4520/M10				-	-	10	-	12					
4520/M12				-	-	12	-	14					
4520/4				-	1/2"	-	5/8"	16					

**TABLE 10: Dimensions and Weights of Strainers**

Catalogue Number	Dimensions [mm]		Weight [g]
	Ø D	L	
4510/3	52	110	195
4520/3		109	
4520/M10		113	205
4520/M12		122	215
4520/4			

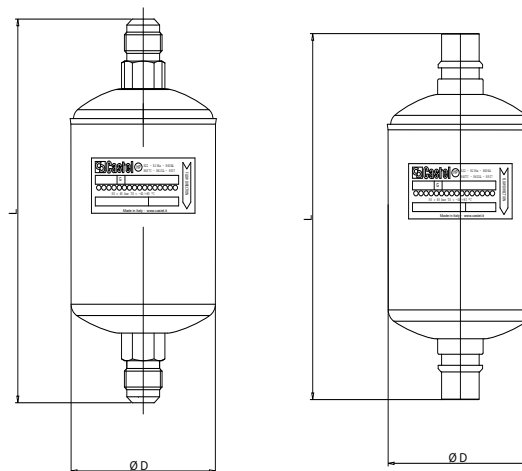

■ 4510

■ 4520

## LIQUID INDICATORS

### APPLICATIONS

The indicators, shown in this handbook, are classified "Pressure accessories" in the sense of the Pressure Equipment Directive 97/23/EC, Article 1, Section 2.1.4 and are subject of Article 3, Section 1.3 of the same Directive.

They are designed for installation on commercial refrigerating systems and on civil and industrial conditioning plants, which use refrigerant fluids proper to the Group II (as defined in Article 9, Section 2.2 of Directive 97/23/EC and referred to in Directive 67/548/EEC).

Liquid indicators ensure inspection of the regular return of oil to the compressor crankcase.

### CONSTRUCTION

Liquid indicators series 38 are manufactured in a total hermetic construction to avoid any possible leaks. The glass "lens", with its proper gasket, is housed into the brass body and is fixed in this seat with an edge calking operation.

The main parts of the indicators are made with the following materials:

- Hot forged brass EN 12420 - CW 617N for body
- Copper tube EN 12735-1 - Cu-DHP for solder connections
- Glass for lens
- PTFE for outlet seal gaskets

### INSTALLATION

The brazing of indicators with solder connections should be carried out with care, using a low melting point filler material. In any case, avoid direct contact between the torch flame and the indicator body or glass, which could be damaged and compromise the proper functioning of the indicator.



■ 3840

**TABLE 11: General Characteristics of liquid indicators**

Catalogue Number	Connections				TS [°C]		PS [bar]	Risk Category according to PED
	Type	SAE Flare	ODS		min.	max.		
			Ø [in.]	Ø [mm]				
3810/22	male - male	1/4"	-	-	- 30	+110	45	Art. 3.3
3810/33		3/8"	-	-				
3810/44		1/2"	-	-				
3840/2	soldering	-	1/4"	-				
3840/3		-	3/8"	-				
3840/M10		-	-	10				
3840/M12		-	-	12				
3840/4		-	1/2"	-				

**TABLE 12: Dimensions and Weights of Liquid Indicators**

Catalogue Number	Dimensions [mm]				Weight [g]
	H	H <sub>1</sub>	L	Ch	
3810/22	22	16.5	71.5	12	115
3810/33	26.5	17.5	77.5	17	150
3810/44	30	18.5	81.5	22	210
3840/2	34	21.5	117	-	120
3840/3					190
3840/M10					225
3840/M12					
3840/4					

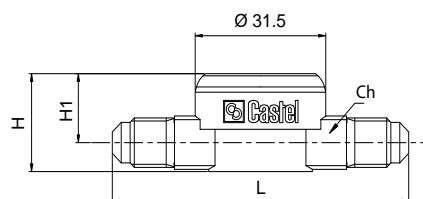

3810 ■

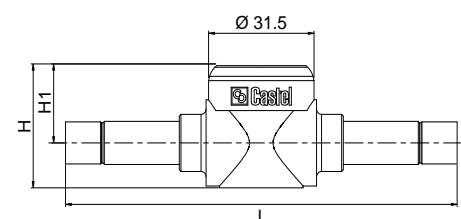

3840 ■







